



# REFRIGERATED SHOWCASES

SERVING THE FOOD INDUSTRY SINCE 1951

## SUSHI CASES WITH CURVED GLASS

Item: 43223  
Model: RS-CN-0043-SC

Item: 43224  
Model: RS-CN-0063-SC

Item: 43225  
Model: RS-CN-0083-SC

Item: 43116  
Model: RS-CN-0103-SC

*Omcans refrigerated sushi cases are perfect for merchandising a variety of sushi, keeping them fresh and delicious. Ideal for sushi bars and restaurants.*



Item: 43116  
RS-CN-0103-SC



Item: 43225  
RS-CN-0083-SC

Item: 43224  
RS-CN-0063-SC

Item: 43223  
RS-CN-0043-SC

Food pan sold separately



**WARRANTY**  
PARTS AND LABOR



Authorized Dealer

# REFRIGERATED SHOWCASES

45-INCH SUSHI DISPLAY CASE RS-CN-0043-SC | ITEM: 43223



## FEATURES

- Brilliant Internal LED illumination on top
- Digital temperature controller and display
- Front Curved glass
- Sliding doors
- Direct cooling system
- Automatic defrost
- Top evaporator with basin to collect condensation
- GN pan can be ordered



## TECHNICAL SPECIFICATION

ITEM NUMBER	43223
MODEL	RS-CN-0043-SC
VOLUME	43 L / 1.48 cu.ft.
POWER	0.18 kW
CONSUMPTION	1.3648 kilowatts per hour / 24h
STORAGE TEMPERATURE	0°C - 12°C / 32 °F - 53.6°F
REFRIGERANT	R290
ELECTRICAL	110V / 60Hz / 1Ph
DIMENSIONS (WDH)	44.5" x 17.7" x 13" / 1130 x 450 x 330 mm
PACKAGING DIMENSIONS	46.7" x 20" x 15" / 1186 x 508 x 381 mm
NET WEIGHT	72.8 lbs. / 33 kg.
PACKAGING WEIGHT	79.4 lbs. / 36 kg.

## TECHNICAL DRAWING AND DIMENSIONS

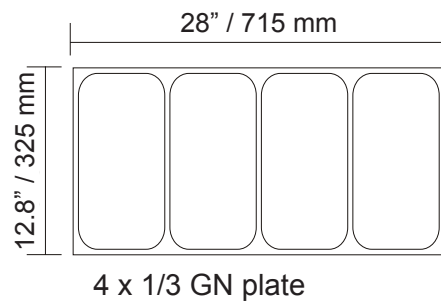
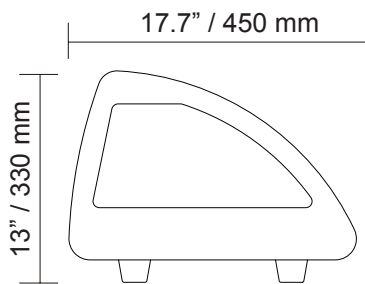

**WARRANTY**  
PARTS AND LABOR



## OMCAN INC.

Telephone: 1-800-465-0234  
Fax: (905) 607-0234  
Email: sales@omcan.com  
Website: www.omcan.com



Follow us to keep up to date with the latest news and offers



2016.E.O.E

# REFRIGERATED SHOWCASES

52-INCH SUSHI DISPLAY CASE RS-CN-0063-SC | ITEM: 43224



## FEATURES

- Brilliant Internal LED illumination on top
- Digital temperature controller and display
- Front Curved glass
- Sliding doors
- Direct cooling system
- Automatic defrost
- Top evaporator with basin to collect condensation
- GN pan can be ordered



## TECHNICAL SPECIFICATION

ITEM NUMBER	43224
MODEL	RS-CN-0063-SC
VOLUME	63 L / 1.84 cu.ft.
POWER	0.18 kW
CONSUMPTION	1.6344 kilowatts per hour/ 24h
STORAGE TEMPERATURE	0°C - 12°C / 32 °F - 53.6°F
REFRIGERANT	R290
ELECTRICAL	110V / 60Hz / 1Ph
DIMENSIONS (WDH)	51.5" x 17.7" x 13" / 1308 x 450 x 330 mm
PACKAGING DIMENSIONS	53.7" x 20" x 15" / 1364 x 508 x 381 mm
NET WEIGHT	79.4 lbs. / 36 kg.
PACKAGING WEIGHT	88.2 lbs. / 40 kg.

## TECHNICAL DRAWING AND DIMENSIONS

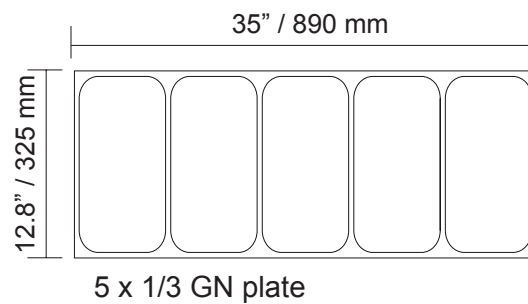
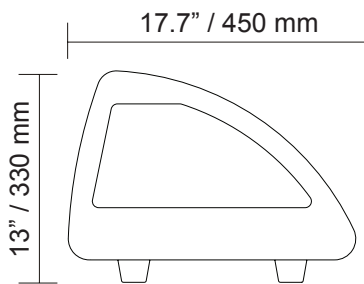

**WARRANTY**  
PARTS AND LABOR



**OMCAN INC.**

Telephone: 1-800-465-0234  
Fax: (905) 607-0234  
Email: sales@omcan.com  
Website: www.omcan.com



Follow us to keep up to date with the latest news and offers



2016.E.O.E

# REFRIGERATED SHOWCASES

58-INCH SUSHI DISPLAY CASE RS-CN-0083-SC | ITEM: 43225



## FEATURES

- Brilliant Internal LED illumination on top
- Digital temperature controller and display
- Front Curved glass
- Sliding doors
- Direct cooling system
- Automatic defrost
- Top evaporator with basin to collect condensation
- GN pan can be ordered



## TECHNICAL SPECIFICATION

ITEM NUMBER	43225
MODEL	RS-CN-0083-SC
VOLUME	83 L / 2.19 cu.ft.
POWER	0.18 kW
CONSUMPTION	1.7365 kilowatts per hour/ 24h
STORAGE TEMPERATURE	0°C - 12°C / 32 °F - 53.6°F
REFRIGERANT	R290
ELECTRICAL	110V / 60Hz / 1Ph
DIMENSIONS (WDH)	58.4" x 17.7" x 13" / 1483 x 450 x 330 mm
PACKAGING DIMENSIONS	60.6" x 20.1" x 15" / 1539 x 510.5 x 381 mm
NET WEIGHT	86 lbs. / 39 kg.
PACKAGING WEIGHT	94.8 lbs. / 43 kg.

## TECHNICAL DRAWING AND DIMENSIONS

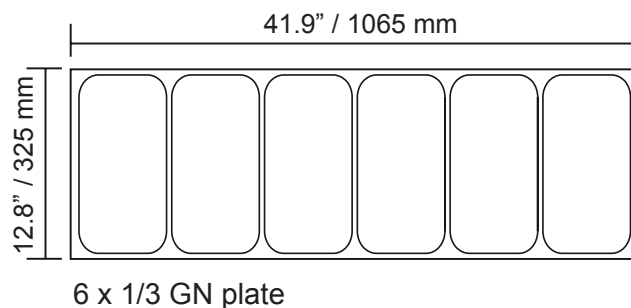
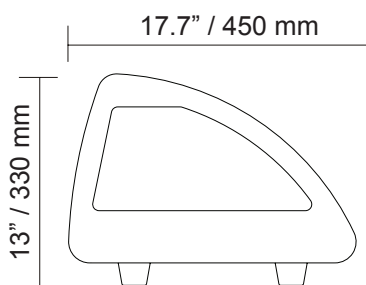

**WARRANTY**  
PARTS AND LABOR



## OMCAN INC.

Telephone: 1-800-465-0234  
Fax: (905) 607-0234  
Email: sales@omcan.com  
Website: www.omcan.com



Follow us to keep up to date with the latest news and offers



2016.E.O.E

# REFRIGERATED SHOWCASES

69-INCH SUSHI DISPLAY CASE RS-CN-0103-SC | ITEM: 43116



## FEATURES

- Brilliant Internal LED illumination on top
- Digital temperature controller and display
- Front Curved glass
- Sliding doors
- Direct cooling system
- Automatic defrost
- Top evaporator with basin to collect condensation
- GN pan can be ordered

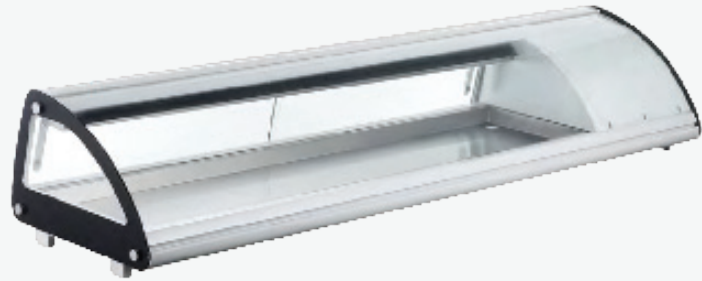

## TECHNICAL SPECIFICATION

ITEM NUMBER	43116
MODEL	RS-CN-0103-SC
VOLUME	103 L / 2.75 cu.ft.
POWER	0.18 kW
CONSUMPTION	1.6814 kilowatts per hour/ 24h
STORAGE TEMPERATURE	0°C - 12°C / 32 °F - 53.6°F
REFRIGERANT	R290
ELECTRICAL	110V / 60Hz / 1Ph
DIMENSIONS (WDH)	69" x 17.7" x 13" / 1754 x 450 x 330 mm
PACKAGING DIMENSIONS	71.25" x 20" x 14.96" / 1810 x 510 x 380 mm
NET WEIGHT	97 lbs. / 44 kg.
PACKAGING WEIGHT	105.8 lbs. / 48 kg.

## TECHNICAL DRAWING AND DIMENSIONS

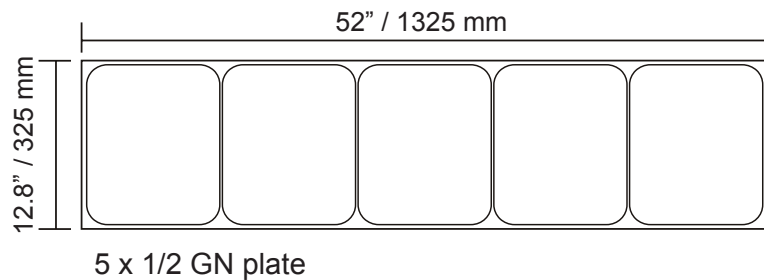
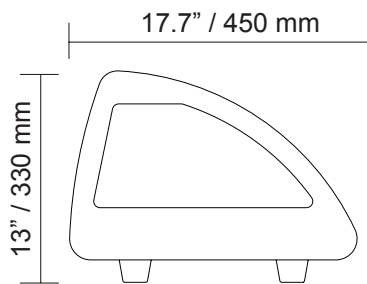

**WARRANTY**  
PARTS AND LABOR



## OMCAN INC.

Telephone: 1-800-465-0234  
Fax: (905) 607-0234  
Email: sales@omcan.com  
Website: www.omcan.com



Follow us to keep up to date with the latest news and offers



2016.E.O.E